



INTERNATIONAL APPLICATION PUBLISHED UNDER THE PATENT COOPERATION TREATY (PCT)

|  |   |   |
|--|---|---|
| <p>(51) International Patent Classification <sup>5</sup> :<br/>G01N 33/487, 27/04</p>  | <p>A1</p>   | <p>(11) International Publication Number: WO 94/23295<br/>(43) International Publication Date: 13 October 1994 (13.10.94)</p> |
| <p>(21) International Application Number: PCT/GB94/00736<br/>(22) International Filing Date: 6 April 1994 (06.04.94)<br/>(30) Priority Data: 9307347.6 7 April 1993 (07.04.93) GB<br/>(71) Applicant (for all designated States except US): ECOSSENSORS LIMITED [GB/GB]; Unit 15, Hanborough Business Park, Long Hanborough, Oxon OX8 8LH (GB).<br/>(72) Inventors; and<br/>(75) Inventors/Applicants (for US only): McALEER, Jerome, Francis [GB/GB]; 52 Nobles Close, Grove, Wantage, Oxon OX12 0NR (GB). ACKLAND, Martin, Robert [GB/GB]; Cedar Cottage, Ginge Road, West Hendred, Wantage, Oxon OX12 8RT (GB).<br/>(74) Agent: NEWBY, John, Ross; J.Y. &amp; G.W. Johnson, Furnival House, 14-18 High Holborn, London WC1V 6DE (GB).</p> | <p>(81) Designated States: CA, GB, JP, US, European patent (AT, BE, CH, DE, DK, ES, FR, GB, GR, IE, IT, LU, MC, NL, PT, SE).<br/><br/>Published<br/><i>With international search report.<br/>Before the expiration of the time limit for amending the claims and to be republished in the event of the receipt of amendments.</i></p> |   |

(54) Title: BIOLOGICAL SPECIES DETECTION METHOD AND BIOSENSOR THEREFOR

(57) Abstract

A method of detection of a species in which the formation of a species-related complex (3, 4, 5) causes displacement of an electrically conductive fluid (29) from a measuring zone (20) and the resultant change in the electrical impedance measured in said zone via electrodes (7 and 8) is used to determine the presence of such a complex. The measuring zone (20) is associated with at least one recess (19) in an electrically insulating substrate (1) and the complex (3, 4, 5) is created on the substrate in or adjacent to the at least one recess (19).

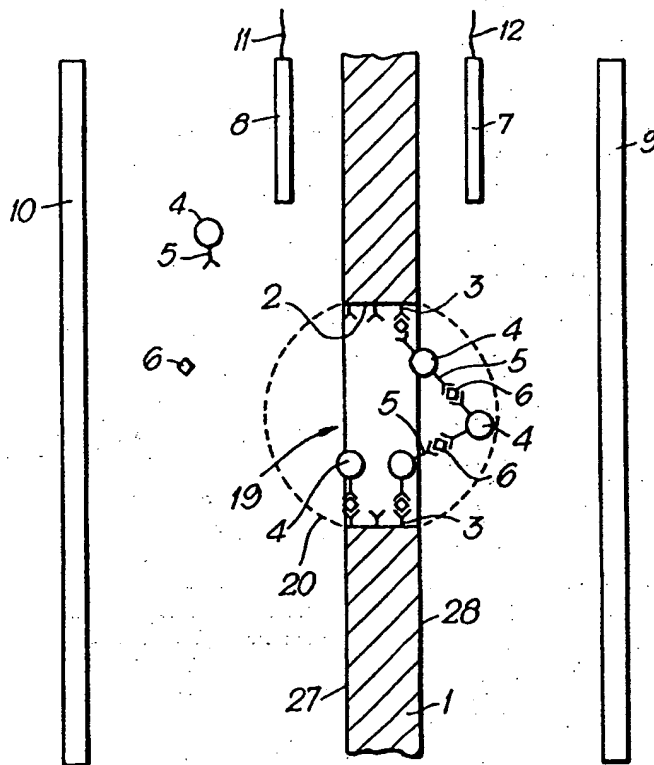

BEST AVAILABLE COPY

**FOR THE PURPOSES OF INFORMATION ONLY**

Codes used to identify States party to the PCT on the front pages of pamphlets publishing international applications under the PCT.

|    |                          |    |                                       |    |                          |
|----|--------------------------|----|---------------------------------------|----|--------------------------|
| AT | Austria                  | GB | United Kingdom                        | MR | Mauritania               |
| AU | Australia                | GE | Georgia                               | MW | Malawi                   |
| BB | Barbados                 | GN | Guinea                                | NE | Niger                    |
| BE | Belgium                  | GR | Greece                                | NL | Netherlands              |
| BF | Burkina Faso             | HU | Hungary                               | NO | Norway                   |
| BG | Bulgaria                 | IE | Ireland                               | NZ | New Zealand              |
| BJ | Benin                    | IT | Italy                                 | PL | Poland                   |
| BR | Brazil                   | JP | Japan                                 | PT | Portugal                 |
| BY | Belarus                  | KE | Kenya                                 | RO | Romania                  |
| CA | Canada                   | KG | Kyrgyzstan                            | RU | Russian Federation       |
| CF | Central African Republic | KP | Democratic People's Republic of Korea | SD | Sudan                    |
| CG | Congo                    | KR | Republic of Korea                     | SE | Sweden                   |
| CH | Switzerland              | KZ | Kazakhstan                            | SI | Slovenia                 |
| CI | Côte d'Ivoire            | LI | Liechtenstein                         | SK | Slovakia                 |
| CM | Cameroon                 | LK | Sri Lanka                             | SN | Senegal                  |
| CN | China                    | LU | Luxembourg                            | TD | Chad                     |
| CS | Czechoslovakia           | LV | Latvia                                | TG | Togo                     |
| CZ | Czech Republic           | MC | Monaco                                | TJ | Tajikistan               |
| DE | Germany                  | MD | Republic of Moldova                   | TT | Trinidad and Tobago      |
| DK | Denmark                  | MG | Madagascar                            | UA | Ukraine                  |
| ES | Spain                    | ML | Mali                                  | US | United States of America |
| FI | Finland                  | MN | Mongolia                              | UZ | Uzbekistan               |
| FR | France                   |    |                                       | VN | Viet Nam                 |
| GA | Gabon                    |    |                                       |    |                          |

- 1 -

**BIOLOGICAL SPECIES DETECTION METHOD AND  
BIOSENSOR THEREFOR**

---

**Background of the Invention**

**1. Field of the Invention**

5 This invention relates to a method and apparatus for the conductimetric determination of biological species (in particular antibodies and antigens).

**2. Description of the Related Art**

The immunological detection of antibodies or antigens  
10 is well known and documented, examples being ELISA and latex agglutination based test kits. In many tests an enzyme is linked to an antibody and subsequent reaction of this enzyme with a suitable substrate results in a colour development. In other examples immunological biosensors have been  
15 constructed where the enzyme produces an electrochemically active species and these have been demonstrated to work. To date, however, only the colour-based systems have been commercially successful

GB-A-2204700 discloses a sensor for chemical species  
20 which uses conductance changes in channels of molecular dimensions. EP-A-0342382 discloses an enzyme linked immunoassay wherein conductance change is a result of enzyme activity causing electrode coating.

US-A-3799743 is concerned with lysis responsive lipid  
25 bilayers in which a binding reaction at the bilayer surface changes the structure and increases conductance. US-A-4191739 measures particle size distribution with a resistive pulse method as particles pass through a hole but is not concerned with changes in solution impedance due to partial  
30 plugging of the hole.

**Summary of the Invention**

According to one aspect of the invention there is

- 2 -

provided a method of detection of a species in which the formation of a species-related complex causes displacement of an electrically conductive fluid from a measuring zone and the resultant change in an electrical parameter measured  
5 in said zone is used to determine the presence of such a complex which is characterised in that the measuring zone is associated with at least one recess in an electrically insulating substrate and the complex is created on the substrate in or adjacent to the at least one recess.

10 By using the present invention, no enzymes are required. Antibodies may be linked to particles such as latex beads to provide mobile antibody-coated particles of appropriate size. These antibody-coated particles in turn  
15 can bind to antibody or antibody-antigen complexes which are bound (e.g. to the inside or edge of a hole of suitable dimension in an appropriate base material, typically a plastic). Thus, when the artefact under test is immersed in a conducting fluid containing antibody-coated particles, and an electric field, which may be alternating, is generated  
20 between two electrodes (e.g. across a hole in a substrate) the impedance can be measured. When the coated particles become bound to the inside or edge of a hole, fluid is displaced with subsequent increase in the impedance across the hole. In this aspect the operation of a biosensor  
25 according to the invention is similar to that of a Coulter Counter in which the passage of a microbe through a small aperture results in a transient impedance change. Unlike the Coulter Counter, however, the aperture in a biosensor according to the present invention is antibody coated  
30 resulting in a permanent impedance change on binding of the analyte the permanence of the change being acceptable because the sensor is disposable after use. Furthermore, since antibody-coated beads may be used, very small target molecules can be detected by the same technique since the  
35 volume exclusion is effected by the coated particles which become attached to the analyte. The change in impedance is a measure of the particle-antibody complex with its

- 3 -

corresponding binding site on the antigen (which may be another antibody). A quantitative measure can be made because as more latex bead-antibody complexes bind, the impedance will continue to change. Many holes can be combined to increase the range of the signal or be used as references to eliminate adverse effects of the environment or sample. Furthermore the internal dimensions and the areal density of holes can be optimised in a biosensor according to the invention to produce the best signal to noise ratio.

The binding event can be assisted by causing the fluid to flow through a hole or increasing the rate of mass transfer across the surface of a hole. Fluid can be caused to flow through a hole by suction or by use of an absorbent pad attached to one surface of the plate containing the hole. Similarly, the use of a filter can be used to ensure the reagents are kept in close proximity with holes and not lost to a bulk test solution.

If the target analyte is itself of sufficient size, for example a micro-organism, it may not be necessary to use particle linked antibodies. In this instance antigenic groups on the surface of the organism can cause the organism to bind to antibodies on the surface of the hole and sufficient fluid can be displaced to effect an impedance change.

If a test solution is caused to flow, for example through a hole or by stirring, then antibodies may be attached to a suitable member, which may be movable, for example a rod or cone. The movable member may be placed in the flowing test solution that contains the antigen of interest where they can bind to the antibodies attached to the member. A second antibody attached to a particle may be introduced to the flow if the antigen is not large enough to displace a suitable volume of liquid. An electric field can then be applied and the impedance changes measured. The

- 4 -

member may move in and out of the field to assist in the measurement or complex formation or to unblock the hole if one is used. (cf. Questor, Difco. UK). To quantify the measurement secured with a biosensor according to this invention an initial impedance value prior to antigen attachment can be measured. Alternatively a reference movable member and electric field can be used to assess changes in resistance.

The roles of antibody and antigen can also be reversed. For example the antigen may be absorbed to the inner surface of the hole to build a system to detect the presence of specific antibodies.

In a further aspect of the invention, no through hole is needed and an electrochemical reaction at a micro-electrode can be used to observe the antibody-antigen binding event. In this aspect the binding of antibodies to antigens result in obstruction of the electrode surface and can be probed using a suitable electrochemically active species.

In a variation of this mode of operation stripping voltammetry can be used as the method of detection. Thus, for example, an electrochemically active labelled antigen can be displaced from a surface bound antibody by a target antigen in competitive immunoassay and made to concentrate at an electrode. The electrode can, for example, be covered with an ion-permeable (e.g. BAFION) film into which the redox labelled species is allowed to concentrate for some time before being determined by either oxidation or reduction. In this way it is possible to capitalise on the sensitivity of electrochemical pre-concentration techniques in combination with the selectivity of an immunoassay method. In a preferred embodiment, the electrode would comprise a microelectrode array formed in an insulating layer onto which the redox labelled antigen-antibody conjugate would be bound. This configuration maximises the

- 5 -

efficiency of capture of the labelled antibody by the electrode. The same configuration could be used if the antigen were labelled with a strongly adsorbing redox species. Displacement of this molecule in the vicinity of the electrode would result in adsorption onto the electrode. Subsequent electrochemical detection of the adsorbed species could then be used to determine the concentration of the original unlabelled antigen.

In a similar configuration, the antigen label need not be redox active, only appropriately charged. If the electrode were to be covered with a suitable material, such as an organic gel, the labelled antigen will partition and concentrate into this material and can then be determined by charge transfer on polarisation of the interface between the electrode covering material and the analyte solution.

A highly sensitive version of the stripping voltammetry methodology involves the use of antibody coated particles of a metal chosen because it can be readily determined by stripping voltammetry. Numerous configurations for such a method are clearly possible. One example is as follows: One antibody to the analyte of interest is bound to a sensor surface and the sensor is then immersed in a sample solution to which metal particles coated with a second antibody to the analyte have been added. In this way, if analyte is present in the sample, the metal particles become attached to the sensor via sandwich formation and their presence can be subsequently determined by stripping voltammetry, either directly or after dissolution. In the latter case the dissolution of the metal can be effected either chemically (e.g. by acidification) or by electrochemical generation of an oxidant (e.g. a more noble metal).

#### Brief Description of the Drawings

Specific embodiments of the invention will now be described, by way of examples, with reference to the accompanying drawings, in which:

- 6 -

Figures 1 and 1A show a single hole arrangement of biosensor, respectively, in schematic cross-section and isometric view,

Figure 2 shows a multiple hole arrangement of biosensor 5 in schematic cross-section,

Figure 3 shows a multiple hole arrangement in plan,

Figures 4 and 4A show arrangements of antibodies and antigens,

Figure 5 shows an alternative arrangement for 10 immobilising antibodies,

Figure 6 shows a simple circuit for the measurement of resistance,

Figure 7 shows a simple arrangement where only one antibody is used,

15 Figure 8 shows an arrangement where a hole is not required,

Figures 9 and 9A show an arrangement consisting of many holes in an insulator on the surfaces of which field generating electrodes have been deposited,

20 Figure 10 shows an arrangement where a multi-analyte array is used,

Figures 11 and 11A show in plan and section, respectively, an alternative to the use of round holes,

Figure 12 and 12A show in plan and section, 25 respectively, an arrangement in which an array of small holes are used to focus the field,



- 7 -

Figures 13 and 13A show two arrangements where the bulk of the fluid does not pass through the holes but passes in a highly turbulent manner across the surface of the sensor,

Figure 14 shows an arrangement where antibodies are coated onto or in the vicinity of at least one micro-electrode,

Figure 15 shows an arrangement in which a labelled antigen is displaced by a target antigen close to one electrode, and

10 Figure 16 shows a further arrangement utilising metal particles trapped in the vicinity of a measuring electrode.

#### Description of Preferred Embodiments

Referring to Figures 1 and 1A, a hole 19 is formed in 15 a plate of suitable electrically insulating material such as plastic or glass 1. To the inside surface 2 and/or in the vicinity of the hole 19 antibodies 3 are attached through adsorption or by another method such as covalent bonding. An electric field is generated across the hole 19 by 20 applying a potential difference between electrodes 7 and 8 in contact with a fluid 29 trapped between plates 9 and 10. The impedance or admittance between these electrodes 7 and 8 measured via their feeding conductors 12, 11 is determined over a sphere 20 of a diameter set by the size of the hole 25 19 extending outwards from the hole 19. The fluid 29 contains antibody-coated particles (e.g. latex beads 4) which, in the presence of the appropriate antigen, are held in place within the sphere 20 by antibody-antigen complexes 3, 4, 5 and 6 in the region of the hole 19. As these 30 complexes 3-6 displace electrolyte, the impedance measured between the electrodes 7 and 8 is altered since this impedance includes the bore of the hole 19 and the complexes contained therein. To ensure that binding takes place within the influence of the sphere 20, the antibodies 3 are

- 8 -

preferably attached to the inner surface 2 of the hole 19.

A multi-hole embodiment of biosensor is shown in Figures 2, 9 and 9A. Many holes 19 can be produced in the base material 1. The bores of some of these holes 19 can be coated with antibody 3. If the bore of a hole 19 is not coated with antibody 3 it can act as a reference to eliminate interferences from both a test solution and the environment. The electrodes 7 and 8 can be formed on surfaces 27 and 28 of the base material 1 in the form of a printed circuit such as the example shown in plan in Figure 3 in which multiple electrodes 8, 13, 15, 17 are used to allow the impedance within each hole 19 to be measured independently.

Figure 4 shows the use of sandwich complexes to cause the latex beads to be held within an appropriate part of the electric field. Figure 4A shows the use of anti-antibodies, for example rat antibodies 3 can be used on the inner surface 2 and rabbit antibodies 5 to rat antibodies can be attached to the particles 4. The rabbit antibodies 5 can only bind to a rat antibody 3 if the antigen 6 has not complexed with the corresponding rat antibody 3. In this case a rise in impedance will indicate the absence of the antigen 6.

Figure 5 shows an arrangement where antibodies can be attached to a movable member 21 that may partly penetrate into a hole 19. The liquid with the antigen 6 to be measured can be sucked or forced through the hole 19. As the fluid passes over the member 21 antigens 6 become attached to the antibodies 3. Antibodies 5 attached to the latex beads 4 are introduced and in turn attach to form complexes 3, 4, 5 and 6. The impedance will increase if antigen 6 is present but not otherwise. If the hole 19 becomes blocked, the member 21, since it is shaped like a cone, can be moved into the hole to remove the blockage. A reference cone can be included to assist in returning the

movable cone to its original position.

Figure 6 shows a simple measuring circuit where the electric field 20 is generated by a voltage source 23 via the conductors 11 and 12 and the electrodes 7 and 8, a 5 voltmeter 24 determining the potential across the electrodes and a sensitive current measuring device 25 measuring the current flowing between the electrodes in parallel with 24.

Figure 7 shows an arrangement where no second antibody 5 or latex beads 4 are required. The antigen 26 used, for 10 example a micro-organism, is sufficiently large to displace enough liquid, by itself, to cause a change in the impedance.

Figure 8 shows an arrangement where no through-hole 19 is needed. The first antibody 3 can now be attached to the 15 outer surface 27 of the base material 1. An electric field is generated between electrodes 7 and 8 as a hemisphere 20a sited above the surface of a binding area 19a. As the antigen-antibody-latex complexes 3, 4, 5, 6 form within the hemisphere 20a the measured impedance between electrodes 7 20 and 8 changes. A cover 30 (e.g. which could be the integer 9 or 10) may be used to confine the hemispherical field 20a and aid measurement. The cover 30 may be movable towards or away from the base material 1 to allow greater access of the antigen 6 to the bound antibody 3.

25 Figures 9 and 9A show an arrangement of biosensor with multiple holes 19. The electrodes 7 and 8 can be formed by depositing a suitable conducting material, for example carbon or gold, onto inner 28 and outer 27 surfaces of the base material 1 and then the holes can be drilled through 30 the entire assembly. In this configuration the field generating electrodes can be very close together so that the impedance between the two electrodes is highly sensitive to events taking place within the respective holes 19.

- 10 -

Figure 10 shows, in cross-section, an arrangement where antibodies to different antigens/analytes are attached to individual holes 19. Each hole is adapted to detect a particular antigenic species, the corresponding antibodies 5 and 33 being attached to the particles 4. If the antigens 6 and 31 are of sufficient size, for example micro-organisms, then the second antibodies 5 and 33 attached to the particles 4 will not be required. A device configured in such a way would be capable of simultaneous determination of several species.

Figures 11 and 11A show an arrangement of biosensor where the holes 19 are not round and the first antibody 3 is attached to a portion of the base material 1 which has holes 19 of various shapes adjacent to it.

15        Figures 12 and 12A show an arrangement of biosensor where a matrix 34 of small holes 19 are used to focus the electrical field. A first antibody 3 can be attached to the surface 27 of the base material 1 in the regions that remain adjacent to the matrix 34 of small holes.

20        Referring to Figures 13 and 13A, the fluid is made to flow along one surface of the device beneath a cover 30 in a manner such that a high mass transfer coefficient is generated, greatly increasing the probability of the analyte being captured. A specific advantage of this geometry is  
25        that a high volume of liquid can be sampled with a high probability of capturing a low concentration of species without the need for time-consuming filtration. The electrodes 7 and 8 coat the layer of base material 1 and a bottom sheet 31 closes the measuring zone from below.

30        Referring to Figure 14, each hole 19 can be formed in an insulating layer 1 on a conductor 7 to produce a micro-electrode or micro-electrode array as described in WO91/08474. The antibody 3 can be bound to exposed areas of the conductor 7 or to the insulating layer. Subsequent

- 11 -

attachment of a target antigen 6 or a particle-antibody-antigen complex 4, 5, 6 results in restricted diffusion, within a diffusion hemisphere 20a, of an electrochemically active marker species E and this restricted diffusion can be sensed electrically as a change in impedance.

Referring to Figure 15, a labelled antigen 6a attached to an antibody 3 is bound in close proximity to a micro-electrode exposed through a hole 19 in a layer 42 overlaying the electrode 7. The labelled antigen 6a is displaced by a target antigen 6 and accumulates either on the electrode surface 7 or, as illustrated, in a layer of film 8 covering the electrode 7. The presence of the labelled antigen 6a can then be determined electrochemically providing an indication of the presence of the target antigen 6.

15 Referring to Figure 16, antibody-coated metal particles 4a become attached to surface bound antibodies 3 via sandwich formation with a respective antigen 6 and held in close proximity with an opening 19 formed in a layer 43 overlaying the electrode 7. The presence of metal is then  
20 determined electrochemically either directly or via mediated electron transfer using another electroactive species such as an electrochemically generated oxidant layer 45 previously coated onto the electrode surface 7.

A convenient way to fabricate any of the above-  
25 described apertured plates is by laser photoablation. (see WO91/08474). Thick film deposition processes can be used in the fabrication of biosensor devices according to this invention.

- 12 -

CLAIMS

1. A method of detection of a species in which the formation of a species-related complex causes displacement of an electrically conductive fluid from a measuring zone  
5 and the resultant change in an electrical parameter measured in said zone is used to determine the presence of such a complex characterised in that the measuring zone is associated with at least one recess in an electrically insulating substrate and the complex is created on the  
10 substrate in or adjacent to the at least one recess.

2. A method according to claim 1, characterised in that the or each recess is a hole and the fluid passes through the at least one hole to aid formation of the complex.

15 3. A method according to claim 1 or claim 2, characterised in that the complex is created on an antibody-coated particle and the particle displaces fluid from the measuring zone.

4. An immunological biosensor where the formation of  
20 surface bound antibody/antigen complexes results in the displacement of a conductive fluid in a measuring zone defined by an electric field causing a permanent change in the electrical impedance measured in said zone.

5. An immunological biosensor as claimed in claim 4,  
25 characterised in that the measuring zone includes at least one hole in an electrically insulating base material, the inner surface of the at least one hole being coated with antibodies.

6. An immunological biosensor as claimed in claim 5,  
30 characterised in that the electric field is generated across at least one hole in a base material which is immersed in a fluid.

- 13 -

7. An immunological biosensor as claimed in claim 4, 5 or 6, characterised in that a second antibody is used and attached to a suitable mobile particle.
8. An immunological biosensor as claimed in claim 5, 6 or 7, characterised in that many holes are provided in the same base material.
9. An immunological biosensor as claimed in claim 8, characterised in that some of the holes act as reference holes.
10. 10. An immunological biosensor as claimed in any one of claims 5 to 8, characterised in that fluid passes through the at least one hole to aid the formation of antibody/antigen complexes.
11. 15. An immunological biosensor as claimed in any one of claims 5 to 8, characterised in that a suitable material overlies the base material to entrap antibodies attached to particles in the fluid.
12. 20. An immunological biosensor as claimed in any one of claims 4 to 11, characterised in that a first antibody is attached to a cone or rod which can move in and out of the electric field.
13. 25. An immunological biosensor as claimed in claim 4 or claim 7, characterised in that the electric field is generated across the surface of a substrate and electrolyte is displaced by antigen/antibody complex formation causing a change in measured impedance of the measuring zone.
14. 30. An immunological biosensor as claimed in claim 10, characterised in that a material is used on the underside of the base material having properties to draw fluid through the at least one hole.

- 14 -

15. An immunological biosensor as claimed in any one of claims 4 to 14, characterised in that at least one hole adjacent to the measuring zone is used to position the electric field.
- 5 16. An immunological biosensor as claimed in claim 8 or claim 13, characterised in that different antibodies are attached to different holes or recesses or regions adjacent thereto to yield a multi-analyte test sensor.
17. An immunological biosensor as claimed in any of 10 claims 5, 6, 8, 9, 10 or 14 to 16, characterised in that the hole(s) in the base material is/are made using laser photoablation.
18. An immunological biosensor as claimed in claim 5, 8 or 15, characterised in that the electric field is focused 15 by a matrix of holes.
19. An immunological biosensor as claimed in claims 8, 11, 16 or 18, where means to enhance mass transfer is provided to increase sensitivity.
20. An immunological biosensor as claimed in any 20 preceding claim, characterised in that the substrate is fabricated by a thick film deposition process.
21. An immunological biosensor comprising a disposable 25 micro-electrode with at least one recess therein and with antibodies attached in sufficient proximity to the at least one recess that antigen binding can be observed as a permanent change in steady state current due to electrochemical oxidation or reduction of an appropriate marker species.



Fig.1.

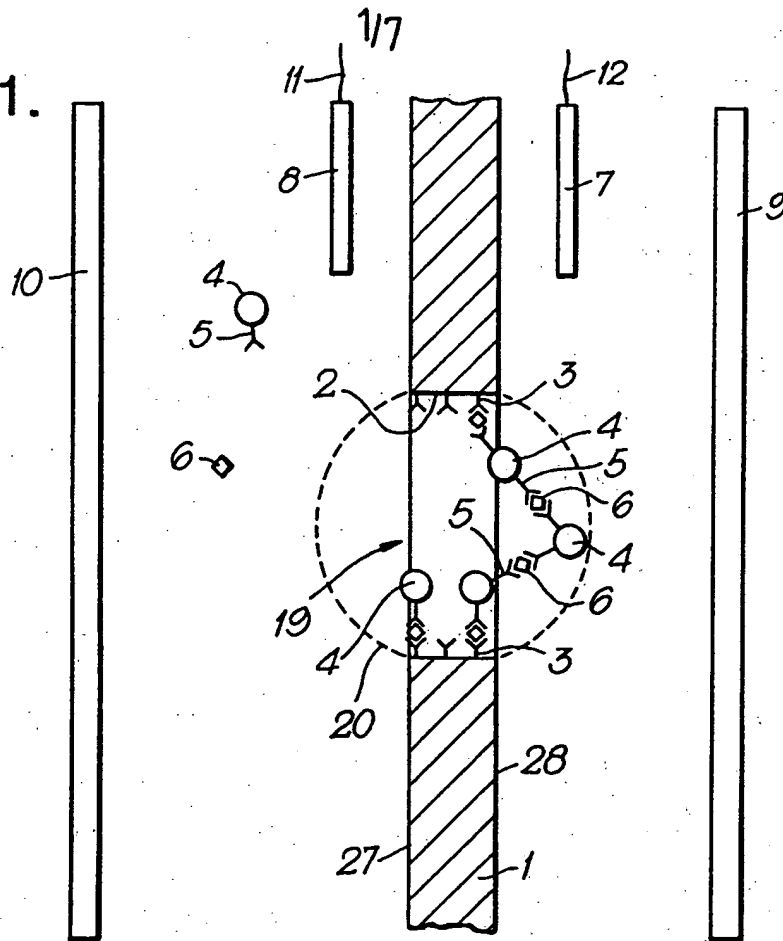
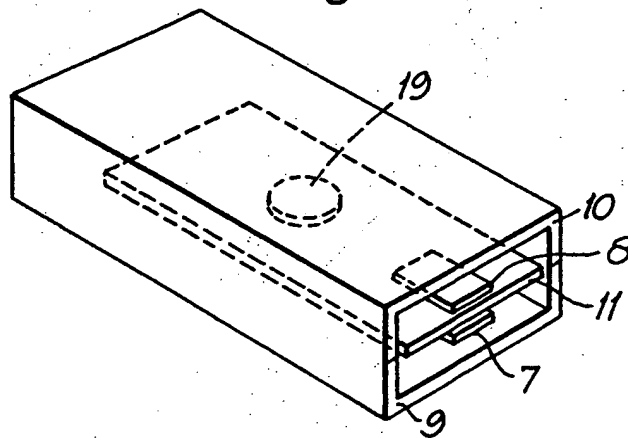

Fig.1A.



SUBSTITUTE SHEET (RULE 26)

Fig.2

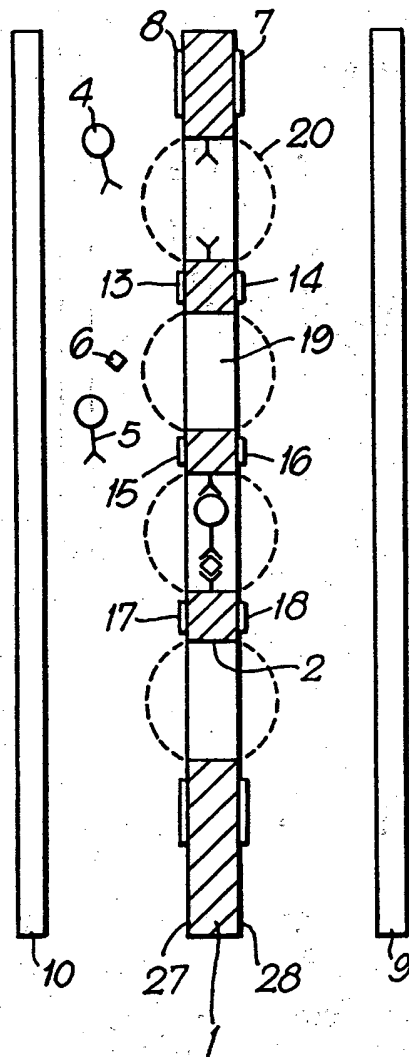

Fig.3.

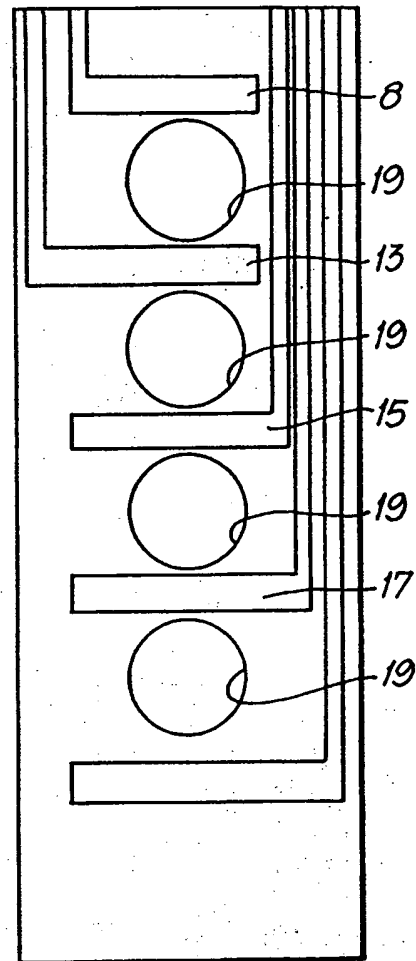

Fig.4.

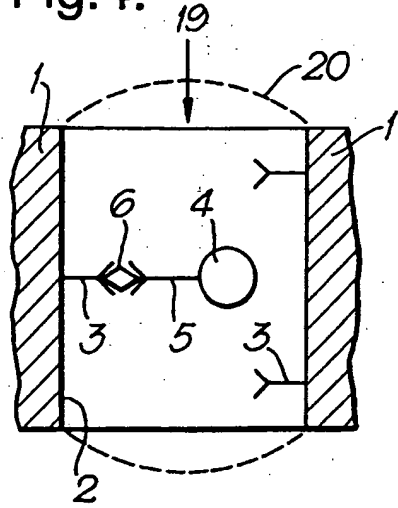

Fig.4A.

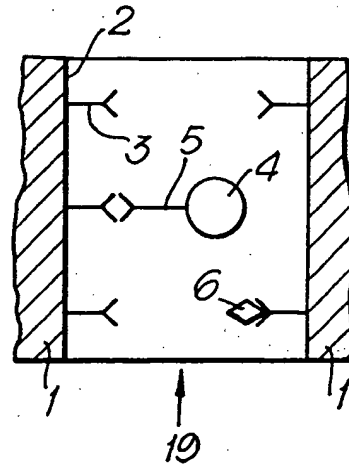
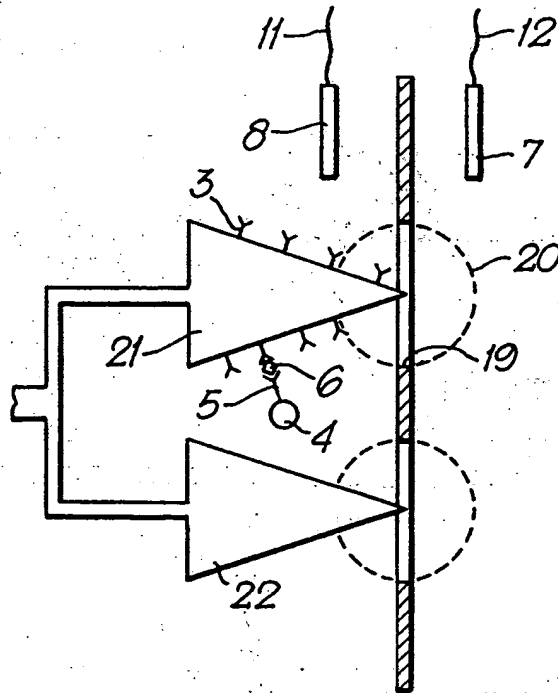

Fig.5.



4/7

Fig.6.

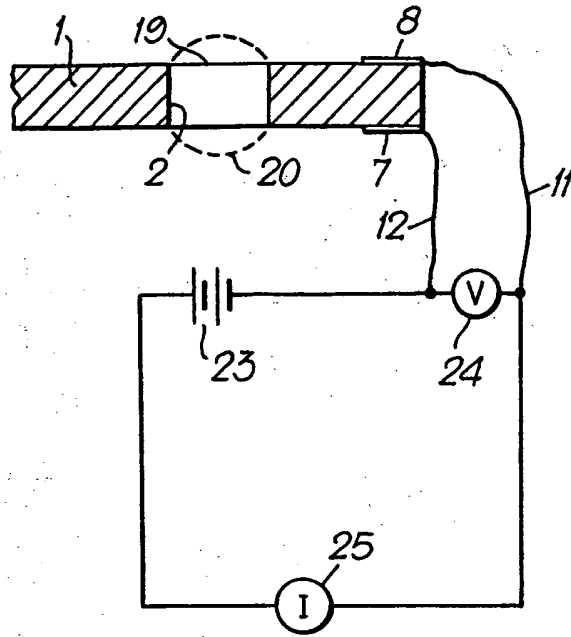

Fig.7.

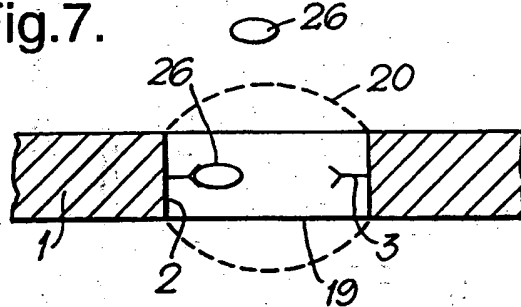
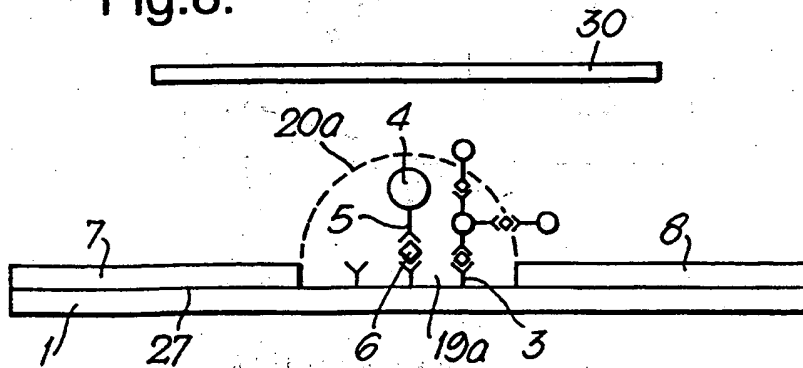

Fig.8.



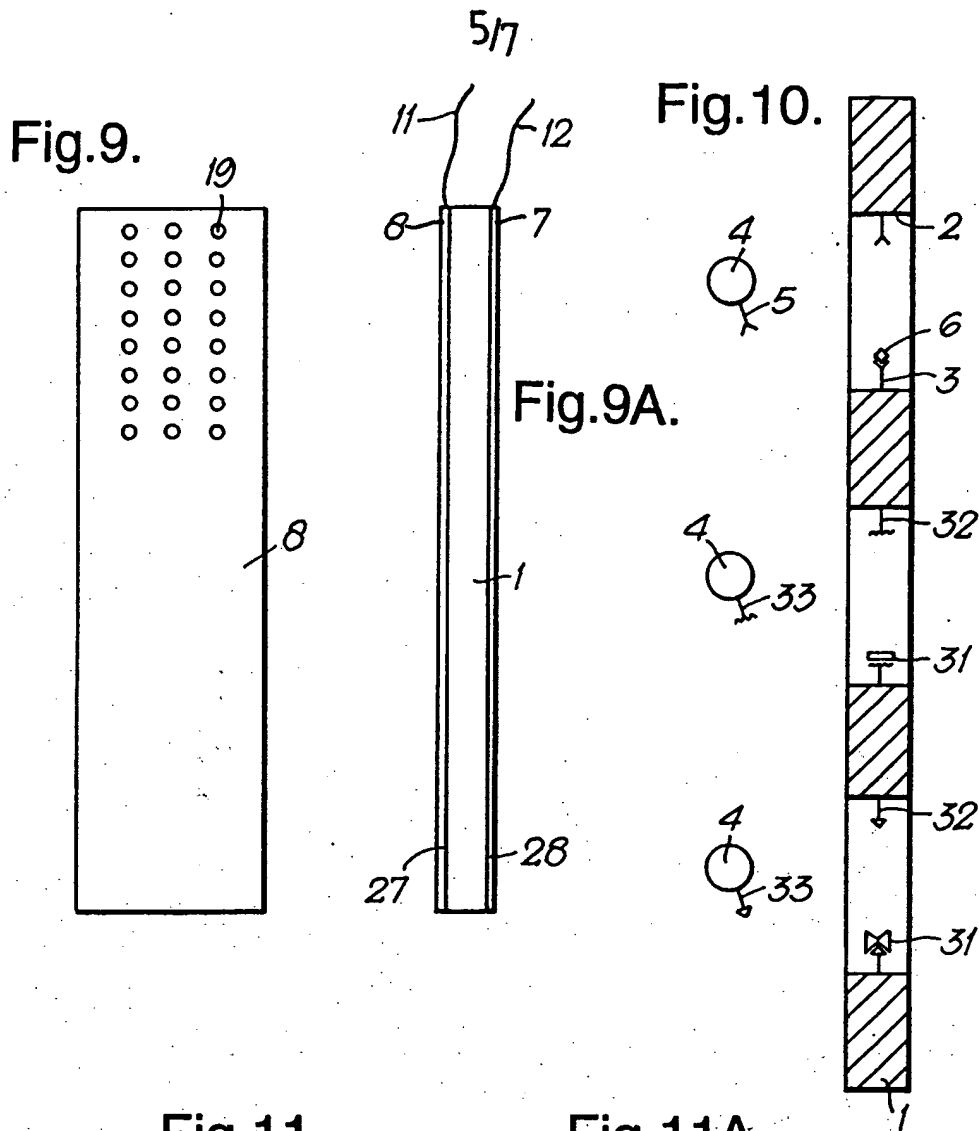

Fig.12.

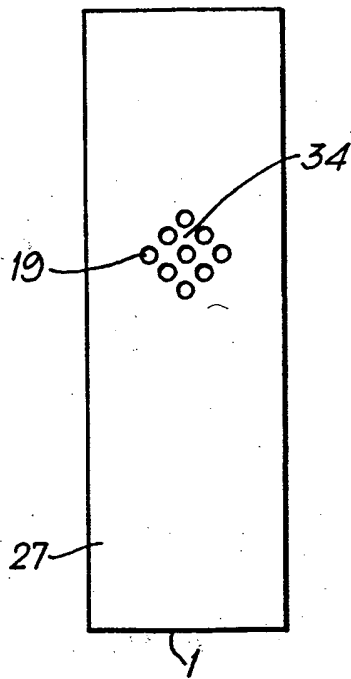
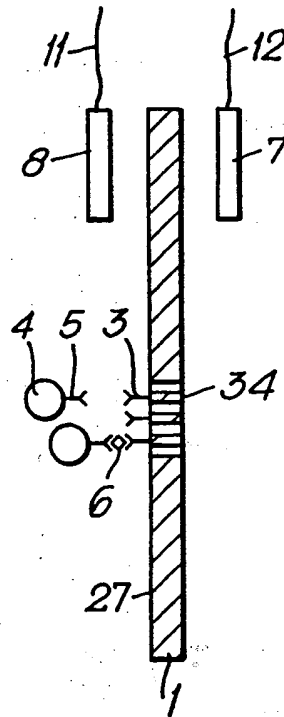

Fig.12A.



7/7

Fig.13.

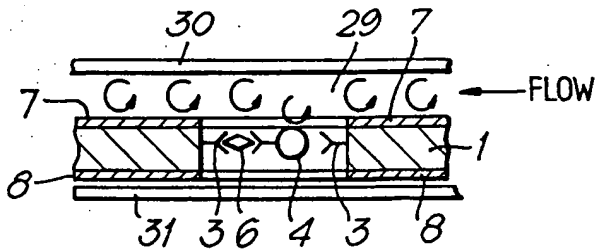

Fig.13A.

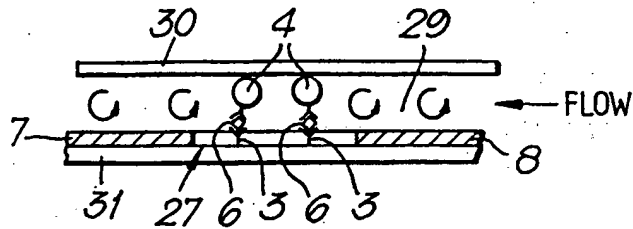

Fig.14.

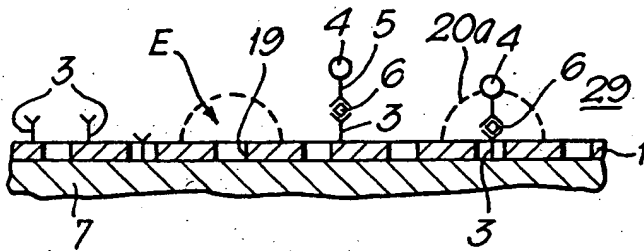

Fig.15.

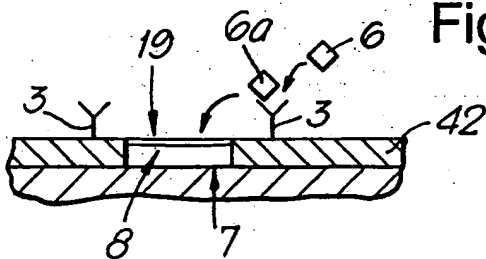
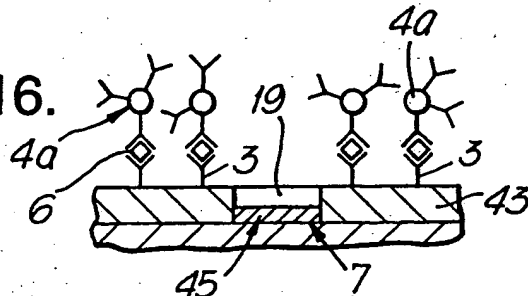

Fig.16.



INTERNATIONAL SEARCH REPORT

International application No.  
PCT/GB 94/00736

A. CLASSIFICATION OF SUBJECT MATTER  
IPC 5 G01N33/487 G01N27/04

According to International Patent Classification (IPC) or to both national classification and IPC:

B. FIELDS SEARCHED

Minimum documentation searched (classification system followed by classification symbols)  
IPC 5 G01N

Documentation searched other than minimum documentation to the extent that such documents are included in the fields searched

Electronic data base consulted during the international search (name of data base and, where practical, search terms used)

C. DOCUMENTS CONSIDERED TO BE RELEVANT

| Category * | Citation of document, with indication, where appropriate, of the relevant passages | Relevant to claim No. |
|------------|--|-----------------------|
| X          | WO,A,90 05300 (MIDWEST RESEARCH TECHNOLOGIES) 17 May 1990                          | 1,3,4                 |
| A          | see the whole document   | 2,5-16, 21            |
| A          | DE,A,30 28 569 (KAUFMANN, KONRAD) 25 February 1982<br>see the whole document       | 1,4,21                |
| A          | US,A,4 997 526 (ROBBLEE) 5 March 1991<br>see the whole document                    | 1,4,21                |
| A          | EP,A,0 311 768 (OHMICRON CORPORATION) 19 April 1989<br>see the whole document      | 1,4,21                |
|            | -/--   |                       |

Further documents are listed in the continuation of box C.  Patent family members are listed in annex.

\* Special categories of cited documents :

"A" document defining the general state of the art which is not considered to be of particular relevance

"B" earlier document but published on or after the international filing date

"I" document which may throw doubts on priority claim(s) or which is cited to establish the publication date of another citation or other special reason (as specified)

"O" document referring to an oral disclosure, use, exhibition or other means

"P" document published prior to the international filing date but later than the priority date claimed

"T" later document published after the international filing date or priority date and not in conflict with the application but cited to understand the principle or theory underlying the invention

"X" document of particular relevance; the claimed invention cannot be considered novel or cannot be considered to involve an inventive step when the document is taken alone

"Y" document of particular relevance; the claimed invention cannot be considered to involve an inventive step when the document is combined with one or more other such documents, such combination being obvious to a person skilled in the art.

"&" document member of the same patent family

Date of the actual completion of the international search  
25 July 1994

Date of mailing of the international search report  
25.08.94

Name and mailing address of the ISA  
European Patent Office, P.O. 5818 Patentlaan 2  
NL - 2280 HV Rijswijk  
Tel. ( + 31-70) 340-2040, Tx. 31 651 epo nl,  
Fax ( + 31-70) 340-3016

Authorized officer  
Bosma, R



INTERNATIONAL SEARCH REPORT

International application No.  
PCT/GB 94/00736

| C.(Continuation) DOCUMENTS CONSIDERED TO BE RELEVANT |   |                       |
|--|---|-----------------------|
| Category   | Citation of document, with indication, where appropriate, of the relevant passages                  | Relevant to claim No. |
| A  | DE,A,36 34 573 (MESSERSCHMITT-BÖLKOW-BLOHM GMBH) 22 October 1987<br>see the whole document<br>----- | 1,4,21                |
| A  | US,A,3 799 743 (ALEXANDER) 26 March 1974<br>cited in the application<br>-----                       | 1,2,4,21              |

1

**INTERNATIONAL SEARCH REPORT**

Information on patent family members

International application No.

PCT/GB 94/00736

| Patent document cited in search report | Publication date | Patent family member(s)          | Publication date     |
|--|------------------|----------------------------------|----------------------|
| WO-A-9005300                           | 17-05-90         | AU-A- 4647589<br>CA-A- 2002660   | 28-05-90<br>10-05-90 |
| DE-A-3028569                           | 25-02-82         | NONE                             |                      |
| US-A-4997526                           | 05-03-91         | NONE                             |                      |
| EP-A-0311768                           | 19-04-89         | US-A- 4916075                    | 10-04-90             |
| DE-A-3634573                           | 22-10-87         | DE-A- 3776679<br>EP-A, B 0263948 | 26-03-92<br>20-04-88 |
| US-A-3799743                           | 26-03-74         | NONE                             |                      |

**This Page is Inserted by IFW Indexing and Scanning  
Operations and is not part of the Official Record**

**BEST AVAILABLE IMAGES**

Defective images within this document are accurate representations of the original documents submitted by the applicant.

Defects in the images include but are not limited to the items checked:

- BLACK BORDERS**
- IMAGE CUT OFF AT TOP, BOTTOM OR SIDES**
- FADED TEXT OR DRAWING**
- BLURRED OR ILLEGIBLE TEXT OR DRAWING**
- SKEWED/SLANTED IMAGES**
- COLOR OR BLACK AND WHITE PHOTOGRAPHS**
- GRAY SCALE DOCUMENTS**
- LINES OR MARKS ON ORIGINAL DOCUMENT**
- REFERENCE(S) OR EXHIBIT(S) SUBMITTED ARE POOR QUALITY**
- OTHER:** \_\_\_\_\_

**IMAGES ARE BEST AVAILABLE COPY.**

**As rescanning these documents will not correct the image problems checked, please do not report these problems to the IFW Image Problem Mailbox.**

This Page Blank (uspto)